

GW4260



**LAVA-VETRERIA DA 60 CM
CON ASCIUGATURA AD ARIA CALDA FORZATA**

INDICE DELLE REVISIONI

WA	A	A
A	A	A
A	A	A
A	A	A
A	A	A
A	A	A

CARATTERISTICHE GENERALI

- A A A
- A A A A A A
- A A A AA AA A A A
- A A A A A A A A A A A A
- A A A A A A A A

A
A

INTRODUZIONE

A A A A A A A A A A A A A A A A
A A A A A A A A A A A A A A A A A A
A A A A A A A A A A A A A A A A A
A A A A A A A A A A A A A A A A A
A A A A A A A A A A A A A A A A A
A A A A A A A A A A A A A A A A A
A A A A A A A A A A A A A A A A A
A A A A A A A A A A A A A A A A A
A A A A A A A A A A A A A A A A A
A A A A A A A A A A A A A A A A A
A A A A A A A A A A A A A A A A A
A A A A A A A A A A A A A A A A A
A A A A A A A A A A A A A A A A A
A A A A A A A A A A A A A A A A A
A A CA A A A A A A A A A A A A A A
A A A A A A A A A A A A A A A A

A

CARATTERISTICHE TECNICHE



A

A A A A A A A A A A A A

A A A A A A A A A A A A

A A A A A A A A A A A A

A A A A A A A A A A A A

A A A A A A A A A A A A

A A A A A A A A A A A A

A A A A A A A A A A A A

A A A A A A A A A A A A

A A A A A A A A A A A A

A A A A A A A A A A A A

A A A A A A A A A A A A

A A A A A A A A A A A A

A
A
A
A
A
A
A
A



A
ELETTRONICA DI CONTROLLO



A	A A A
A A	A
A A A	A
A A A	A
A	A A A A A A A A A A A A
	A A A A A A A A A A A A
	A A A A A A A A A A A A
	A A A A A A A A A A A A
	A A A A A A A A A A A A
	A A A A A A A A A A A A
G A A	A A A A A A A A A A A A
G A A	A A A A A A A A A A A A
	A A A A A A A A A A A A
	A A A A A A A A A A A A
W A A A	A A A A A A A A A A A A
	A A A A A A A A A A A A
A	A A
A A A A	AA A A AA ACA A A

A

▪ A AA A AA A A A A A A A A A A A A

A A A A A A A A A A A A A A A A

— A A A A A A A A A A A A A A A A

— A A A A A A A A A A A A A A A A

— A A A A A A A A A A A A A A A A

— A A A A A A A A A A A A A A A A

— A A A A A A A A A A A A A A A A

— A A A A A A A A A A A A A A A A

A

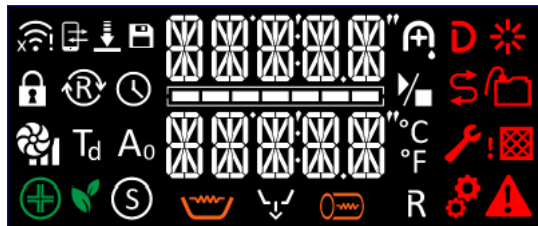

A

- A
- A A A A A A A A AA A A A A A A
A AA A AAA A A A A A A A
- A
- I programmi standard sono n. 20 e i programmi personalizzabili secondo le esigenze del cliente sono n. 20 A A A A A A A A
 - A può essere composto fino a n. 10 fasi di lavaggio/risciacquo + n. 1 fase per l'asciugatura A
 - A A AA A A A A A A AA A A A
 - A A A A AA A A A A A A A A
 - A A A A A A A A A A A A A
 - Controllo del dosaggio dei detergenti mediante sensori di flusso, sensori di livello e temporizzatore A
 - A A A A A A A A
 - AA A A A A A A A
 - W A A A AA A A
 - A A A A A A
 - A CA AA A A A A A A AA A A
 - A A A AA A AA A AA A A AA A A A
 - A A A AA A A A A A A A
 - AA A A A A A A A A A A A
 - A A A A A A A A A A A A A A
 - A A A A A A A A A A A A A A
 - A A A A A A A A A A A A A A
 - A A A A A A A A A A A A A A
 - A A A A A A A A A A A A A A
 - A A A A A A A A A A A A A A
 - A A A A A A A A A A A A A A
- A

A

SICUREZZE E INDICAZIONI DI ALLARME

- C A A A A A A A A A A A A A
- A A A
- A A A A A A A A A A A
- A A A A A A A A A A
- A A A A A A A A A A
- W AA AA AA AA A
- A A A A A A
- A A A A
- A A A A A A A A
- A A A A A A A A A A A A
- A A A A A A A A A A A A
- A A A A A A A A A A A A
- AA A A A A A A
- A A A
- A A A A
- A A A A A A A A A A A A
- A A A A A A A A A A A A A A A A
- N A A A A A A A A
- A A A A A A

SISTEMA DI LAVAGGIO

A		A	A	A	A	A	A	A	A	A	A	A	A	A	A	
		A	A		A	A										
A		A	A		A	A	A	A	A	A	A	A			A	A
		A	A		A	A	A	A	A	A	A	A	A		A	A
A		A	A		A	A				A	A	A		A	A	A
		A	A	A		A	A	A	A	A	A					
		A		A	A	A	A	A	A	A	A					
		A		A	A	A	A	A	A	A	A	A				
		A	A		A	A	A	A	A	A	A	A				
		A		A	A	A	A	A	A	A	A	A				
		A	A		A	A	A	A	A	A	A	A				
A		A	A		A	A	A	A	A	A	A	A	A			
		A	A		A	A	A	A	A	A	A	A				
		A	A		A	A	A	A	A	A	A	A				
		A	A		A	A	A	A	A	A	A	A				
		A	A		A	A	A	A	A	A	A	A				
A		A	A		A	A	A	A	A	A	A	A				
		A	A		A	A	A	A	A	A	A	A				

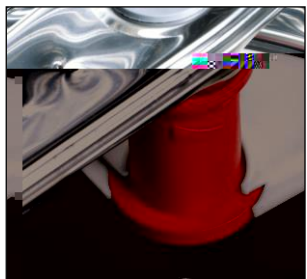

FILTRI

- **Quadruplo filtro in vasca:**
 - N A A A A A A
 - N A A A AA A A
 - G A A A A A A
 - N A A A A A
 - A A A A A
 - A A A A A
- A
A

A



SISTEMA DI DOSAGGIO DEI PRODOTTI CHIMICI UTILIZZABILI

AA A A AA AA A A AA A A A
 A A A

A

- in funzione della configurazione AA A A A oppure AA A A A
- A A A A A A A A A A A A A A A A

A

- A A A A AA A A AA A A A A A A A A

A

- AA AA A A A A AA A A A A A A A A
- A A A A A A AA A A A A

A

- AA A

A

- A A A A AA AA A A A A

A

- AA A A A A A A A A A A A A A A A A
- A A A A A A AA AA A A A A A A A A A A
 AA A A AA A A A A AA A A A AA A A A A
 A

A

- A A A A A A A A A A A A

A

A

A



CONDENSATORE DI VAPORE

A AA AA A AA A A A A A A A A A A A A
 A AA AA AA A AA A A A A A A A A A A A A
 A
 AA AA AA A A A A A A A A A A A A A A A A A A
 AA A AA A A A A A A A A A A A A A A A A A A A

A

A

A

A



SISTEMA DI ASCIUGATURA

A A A A A A A A A A A A A A A
AA
A A A A A A A A A A A A A A A A
A A A A A A A A A A A A A A A
A A A A A A A A A A A A A A A
A A A A A A A A A A A A A A A
A A A A A A A A A A A A A A A
A A A A A A A A A A A A A A A
A A A A A A A A A A A A A A A

A

A A A A A A A A
A
■ A A A AA A A A
■ A A A A A A A A A
A
A AA A A A A A A A A A A A A
A AA A A AA A A A A A A A
A
■ A A A A A

A
A

ALLACCIAMENTO ELETTRICO

AA A A A A AA A A A A AA A A A A A A
A A A A A A A A A A
A
■ VA A A A A AAAA A
A
■ W A A AA A A A A A
■ W A A A A WA AA AA A A

A
A

ALLACCIAMENTI IDRICI

(PRESSIONE 1-6 bar - collegamento 3/4" DN20 – PORTATA RICHIESTA 4÷12 l/min)

▪ **Allacciamento idrico acqua fredda:**

- A A
- AG G A A
- A A
- A A A A A A A A AA A A

▪ **Allacciamento idrico acqua calda (opzionale):**

- A A
- AG G A A
- A A

▪ **Alimentazione acqua demineralizzata:**

- A A
- A A AA A A
- AA A A
- A A
- A A A

- AA A A A A A A A A A A A
- A A A A A AA A
- A AA A A A A A A A A A A
- A A A A A A AA A AA A A A
- A A A A A A A A A A A
- A A A A A A AA AA A

A

CONNESSIONE SCARICO

A

- A AA A A AA A A A A A A
- A A A A
- A A A A A A A A A A A A
- A AA A A
- A A A A A A A A A A A A A A A A
- A A A A A A A A A A A A A A
- AA AA A

A

A

A
RUMOROSITÀ

- N A AC A

A
A

DIMENSIONI LxPxH E PESI

- A A A A A AA A AA AA A A A A
- A A A A AA AA A A
- W A A A A A A
- A A A A
- A A A A
- A AA A A A

A
A

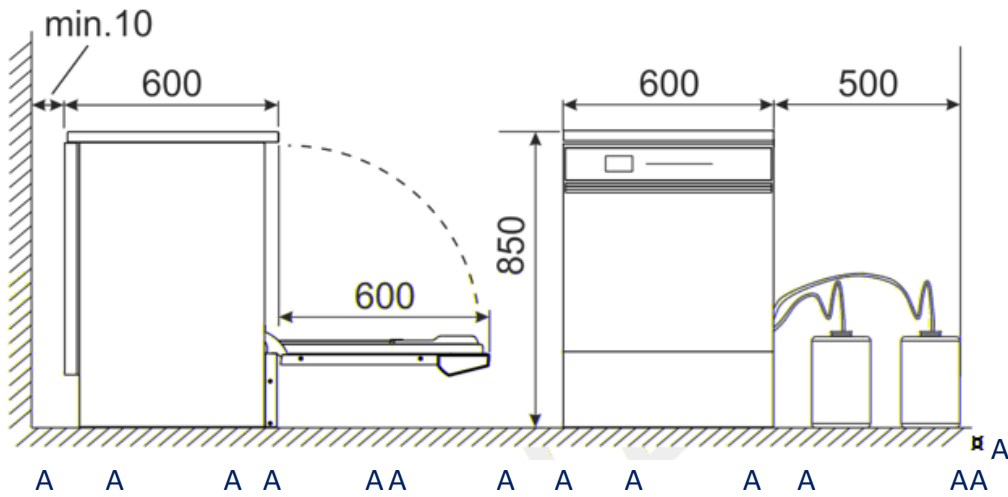

- A A A A A AA A A A A A AA A A A

A
A
A
A
A
A
A
A
A
A
A



A
 A A A A A AA A AA A A
 AA AA A A
 A AA A A A A A AA A
 A
 A
 A

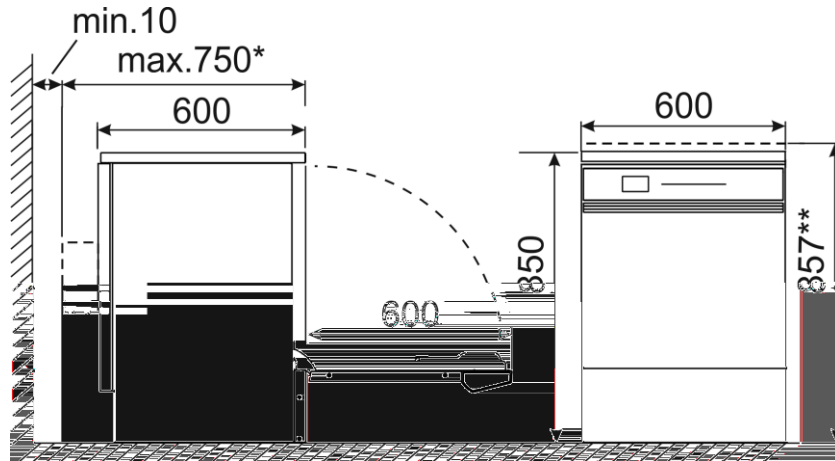

ACCIAIO INOX

▪ W A AA A A A AA A AA A AA A AA
 A A A A A A A A A A A A A A A A A
 A A
 ▪ A A A A A A A A A A A A A A A A A
 A A A A A A A A A A A A A A A A
 AA A
 ▪ A A A A A A A A A A A A A A A A
 A A A A A A A A A A A A A A A A
 ▪ A AA AA AA AA AA AA AA AA AA AA AA
 A

A

FUNZIONI AUSILIARIE

- A CA A A A A A A
 - A A A A A A A
 - A A A A AA A A A
- A A A A A A A A A A A A A A A
- A A A A A A A A A A A A A A A
- A A A A A A A A A A CA A A A A A A A A A
- A A A A A A A A A A A A A A A
- A A A A A A A A A A A A A A A

A

A

TRACCIABILITA' DEL PROCESSO



A A A A A A A A A A A A A A A

A A A A A A A A A A A A A A A

A A A A A A A A A A A A A A A

A A A A A A A A A A A A A A A

A A A A A A A A A A A A A A A

A



CONNESSIONE LAN

A A A A A A A A A A A A A A A

A A A A A A A A A A A A A A A

A A A A A A A A A A A A A A A

A A A A A A A A A A A A A A A

A A A A A A A A A A A A A A A

A A A A A A A A A A A A A A A

OPTIONAL DISPONIBILI

- A A A AG A
- A A A A A
- A A A A A A A A A A
- A A A A A A A A A A A A
- A A A A A A A A A A A A
- A A A A A A A A A A A
- C A A A A A A A A A A A
- A A A A A A A A A A
- A A A A A A A A A A A
- A A A A A A A A A A A A A A
- A A A A A A A A A A A A A A
- A A A A A A A A A A A A A A
- A A A A A A A A A A A A A A
- A A A A A A A A A A A A A A
- G A A A G A

A
A



A
GAMMA ACCESSORI – VERSATILITÀ E FLESSIBILITÀ

- A A A A A A A A A A A A A A
- A A A A A A A A A A A A A A
- A A A A A A A A A A A A A A
- AA A A A A A A A A A A A A A A
- A A A A A A A A A A A A A A
- A A A A A A A A A A A A A A
- A A A A A A A A A A A A A A

DETERGENTI ED ADDITIVI

A A A A A AA A A A A A A AA A
A A A A A A A A A A A A A A
A A A A AA A A A A A A A A
A A A A A A A A A A A A A
A A A A A A A AA A A A A A A
A A AA A
A

SERVIZIO DI ASSISTENZA TECNICA



A A A A A A A AA A A A A A
A A A A A A A A A A A
A A A A AA A A A A A A A
A A A A A A A A AA A A A A
A AA A A A A A A A A A A A A
A A A A AA A A A A A A A A A
A
A

GARANZIA

A AA A A A A AA A